

API Steel Gate Valve

TEK VALVE

Steel Gate Valve

TEK VALVE

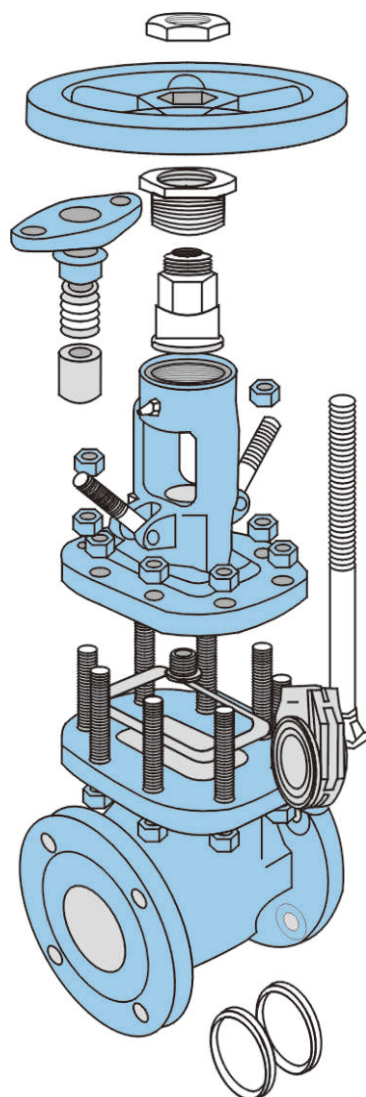

Standards

Design and Manufacture: Cast steel gate valve to API600 (ISO 10434) ; Cast stainless steel gate valve to API 603 or API 600; Forged steel gate valve to API 602. Inspection and Test: API 598.

End flange dimension: ASME B16.5 for NPS 24J; ASME B16.47 series B, ASME B16.47 series A, MSS SP-44 for NPS 24J.

BW end dimension: ASME B16.25.

Socket-weld dimension: ASME B16.11.

Face to face and end to end: ASME B16.10.

Pressure-temperature ratings: ASME B16.34.

Gasket of Cover Flange

Stainless steel + flexible graphite combined gasket is used for Class 150 and Class 300 gate valve; Stainless steel + flexible graphite wounded gasket is used for Class 600 gate valve and ring joint gasket is also optional for Class 600 gate valve; Ring Joint gasket is used for Class 900 gate valve; Pressurized seal design is used for Class 1500 - Class 2500 gate valve.

Packing Seal

Molded flexible graphite is used for packing material. PTFE or combined packing material can be also used if being requested by the customer. The internal surface of the stuffing box, of which area is contacted with the packing, is of excellent finish (Ra3.2 μm). The stem surface, contacting with the packing, should be rolled and pressed after being precisely machined, so as to reach to the high finish and compactness (Ra0.8 μm) and ensure the reliable tightness of the stem area.

Back Seating Design

All our gate valves have the back seating design. In most cases, the carbon steel gate valve is fitted with a renewable back seat. For stainless steel gate valve, the back seat is machined directly in the bonnet or is machined after welding. When the gate valve is at fully open position, the sealing of the back seat can be very reliable. However, as per the requirement of API 600, it is not advisable to add or change packing by the mean of back seating when the valve is Pressure containing.

Stem Design

The stem is of integral forged design. The minimum diameter of the stem shall per the standard requirement. The connection of the stem and disc is T type. The strength of the connecting area is bigger than that of the T threaded part of the stem. The strength test of that area conforms to API 591.

API SERIES

API Steel Gate Valve

TEK VALVE

API SERIES

◎ Body and Bonnet Connection

The body and bonnet of Class150 ~ Class900 gate valves are usually connected with studs and nuts. And the body and bonnet of Class1500 ~ Class2500 gate valves are usually of pressure seal design.

√ Design of Disc

Gate Valves with NPS ≥ 2 are of wedge flexible gate;
Gate valves with NPS < 2 are of wedge solid gate.

◎ Actuation

Hand wheel or gear box is usually used for gate valve actuation. Chain wheel and electric actuator can be also used for gate valve actuation if being requested by the customers.

◎ Stem Nut

Usually, the stem nut is made of copper alloy. it is also can be made of ASTM A439 D2 if being requested by the customer. For large sized gate valves (NPS 10 for Class 150, NPS 8 for Class 300, NPS 6 for Class 600, NPS 5 for Class 900), rolling bearing is fitted at the two sides of the stem nut in order to minimize the open and close torque of the gate valve.

◎ Seat

For carbon steel gate valve, the seat is usually forged steel. The sealing surface of the seat is spray welded with hard alloy specified by the customer. Renewable threaded seat is used for NPS ≤ 10 gate valves, and welded on seat can be also optional if being requested by the customer. Welded on seat is used for NPS ≤ 10 carbon steel gate valves. For Stainless steel gate valve, integral seat is usually adopted, or to weld hard alloy directly integrally. Threaded or welded on seat is also optional for stainless steel gate valve if being requested by the customer.

√ Belleville Spring Loaded Packing Impacting System

If being requested by the customer, the Belleville spring loaded packing impacting system can be adopted for enhancing the durability and reliability of the packing seal.

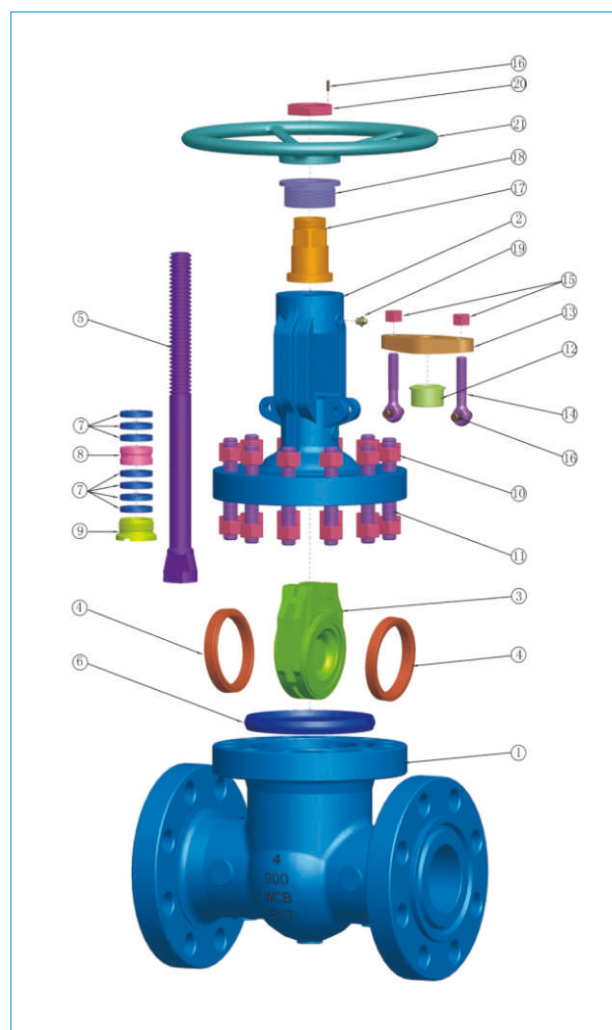

No	Part Name	No	Part Name	No	Part Name
1	Body	8	Lantern Ring	15	Gland Nut
2	Bonnet	9	Backseat Bushing	16	Pin
3	Wedge	10	Nut	17	Stem Nut
4	Seating Ring	11	Bolt	18	Retaining Nut
5	Stem	12	Gland	19	Nipple
6	Gasket	13	Gland Flange	20	H.W.Lock Nut
7	Stem Packing	14	Gland Eyebolt	21	Handwheel

API Steel Gate Valve

TEK VALVE



Trim material			
Trim code	Seat ring surface	Wedge seat surface	Stem & backseat bushing
1	13Cr	13Cr	A182 F6a
2	18Cr-8Ni	18Cr-8Ni	A182 F304
3	25Cr-20Ni	25Cr-20Ni	A182 F310
4	Hard 13Cr	Hard 13Cr	A182 F6a
5	Stellite	Stellite	A182 F6a
6	13Cr	Cu-Ni Alloy	Monel
7	13Cr	Hard 13Cr	A182 F6a
8	Stellite	13Cr	A182 F6a
9	Cu-Ni Alloy	Cu-Ni Alloy	Monel
10	18Cr-8Ni-Mo	18Cr-8Ni-Mo	A182 F316
11	Cu-Ni Alloy	Cu-Ni Alloy	Monel
12	Stellite	18Cr-8Ni-Mo	A182 F316
13	19Cr-29Ni	19Cr-29Ni	20 Alloy

API SERIES

ASTM Material list of API600 Rising Stem Cast Steel Gate Valve

No	Part Name	Carbon Steel to ASTM		Stainless Steel to ASTM				Alloy Steel to ASTM		
1	Body	A216 WCB	A352 LCB	A351 CF8	A351 CF8M	A351 CF3	A351 CF3M	A217 WC6	A217 WC9	A217 C5
2	Bonnet	A216 WCB	A352 LCB	A351 CF8	A351 CF8M	A351 CF3	A351 CF3M	A217 WC6	A217 WC9	A217 C5
3	Wedge	A216 WCB	A352 LCB	A351 CF8	A351 CF8M	A351 CF3	A351 CF3M	A217 WC6	A217 WC9	A217 C5
4	Seating Ring	A105N	A350LF2	A351 CF8	A351 CF8M	A351 CF3	A351 CF3M	A182 F11	A182 F22	A182 F5
5	Stem	A182 F6a	A182 F304	A182 F304	A182 F316	A182 F304L	A182 F316L	A182 F304		
6	Gasket	Graphite+SS304, PTFE								
7	Stem Packing	Flexible Graphite								
8	Lantern Ring	A182 F6a	A182 F304	A182 F304	A182 F316	A182 F304L	A182 F316L	A182 F304		
9	Backseat Bushing	A182 F6a	A182 F304	A182 F304	A182 F316	A182 F304L	A182 F316L	A182 F304		
10	Nut	A194 2H	A194 4	A194 8				A194 7		
11	Bolt	A193 B7	A320 L7	A193 B8				A193 B16		
12	Gland	F6a	A182 F304	A182 F304	A182 F316	A182 F304L	A182 F316L	A182 F304		
13	Gland Flange	A216 WCB	A352 LCB	A351 CF8	A351 CF8	A351 CF8	A351 CF8	A217 WC6	217 WC9	A217 C5
14	Gland Eyebolt	A193 B7		A193 B8				A193 B16		
15	Gland Nut	A194 2H		A194 8				A194 7		
16	Pin	ANSI 1045		A182 F304				ANSI 1045		
17	Stem Nut	A439 D2 / B148 952A								
18	Retaining Nut	ANSI 1020								
19	Nipple	Copper Alloy								
20	H.W.Lock Nut	ANSI 1020								
21	Handwheel	A197								

※

API Steel Gate Valve

TEK VALVE

Construction feature

- Bolted bonnet
- Flexible or solid wedge
- Renewable seat
- (Threaded or welded seat ring)
- ∇ 8" Yoke integral with bonnet
- ∧ 10" Spereete yoke bolted to bonnet

API598 Pressure Test

- Pressure ratings . . Class150
- Hydraulic Shell test . . 3.2MPa
- Hydraulic Seat test . . 2.2MPa
- Air test . . 0.6MPa

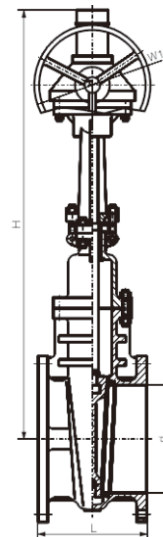
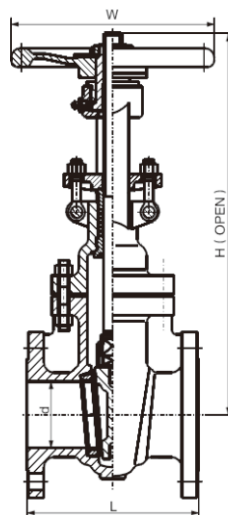

API SERIES

Main size of outside & weight

Class	Size		Dimensions (mm)								Weight (Kg)	
	NPS	DN	L			d	H	H1	W	W1	Hand wheel	Gear box
			RF	RTJ	BW							
Class 150	2	50	178	191	216	51	400	-	200	-	19	-
	2 1/2	65	190	203	241	64	435	-	200	-	25	-
	3	80	203	216	283	76	515	-	250	-	33	-
	4	100	229	241	305	102	595	-	280	-	49	-
	5	125	254	267	381	127	725	-	280	-	62	-
	6	150	267	279	403	152	780	820	300	310	77	104
	8	200	292	305	419	203	975	1020	350	310	123	150
	10	250	330	343	457	254	1150	1200	400	310	188	215
	12	300	356	368	502	305	1380	1430	450	310	288	315
	14	350	381	394	572	337	1545	1580	500	310	385	435
	16	400	406	419	610	387	1733	1780	500	460	500	552
	18	450	432	445	660	438	1915	1990	500	460	601	653
	20	500	457	470	711	489	2122	2220	600	460	764	816
	24	600	508	521	813	591	2520	2600	600	460	1007	1185
	28	700	610	623	914	684	-	3050	-	600	-	1880
	30	750	610	623	914	735	-	3130	-	600	-	2300
	32	800	660	673	965	779	-	3280	-	600	-	2550
	36	900	711	724	1016	874	-	3720	-	600	-	3390
40	1000	762	-	1066	-	-	4100	-	-	-	4880	
42	1050	787	-	1092	-	-	4300	-	-	-	5300	
48	1200	864	-	1168	-	-	5080	-	-	-	7520	

API Steel Gate Valve

TEK VALVE

⦿ **Construction feature**

- Bolted bonnet
- Flexible or solid wedge
- Renewable seat
(Threaded or welded seat ring)
- ✓ 8" Yoke integral with bonnet
- ^ 10" Spearete yoke bolted to bonnet

⦿ **API598 Pressure Test**

- Pressure ratings .. Class300
- Hydraulic Shell test .. 7.8MPa
- Hydraulic Seat test .. 5.7MPa
- Air test .. 0.6MPa

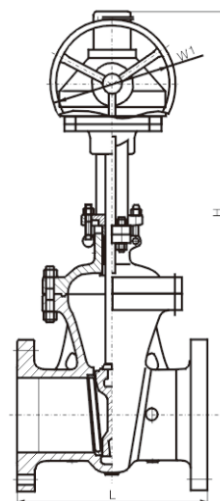
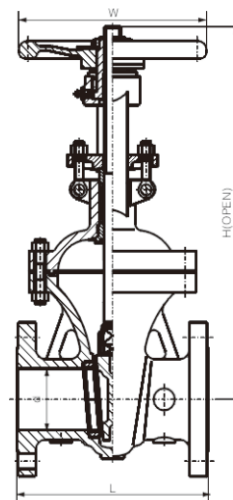
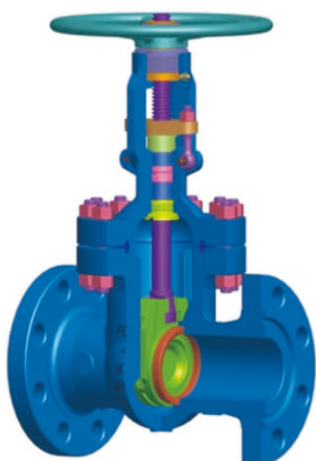

API SERIES

Main size of outside & weight

Class	Size		Dimensions (mm)								Weight (Kg)	
	NPS	DN	L			d	H	H1	W	W1	Hand wheel	Gear box
			RF	RTJ	BW							
Class 300	2	50	216	232	216	51	420	-	200	-	25	-
	2 1/2	65	241	257	241	64	446	-	200	-	30	-
	3	80	283	298	283	76	537	-	250	-	48	-
	4	100	305	321	305	102	619	650	280	310	73	100
	5	125	381	397	381	127	722	750	300	310	99	126
	6	150	403	419	403	152	806	835	350	310	130	186
	8	200	419	435	419	203	1000	1030	400	310	208	235
	10	250	457	473	457	254	1240	1280	450	310	334	386
	12	300	502	518	502	305	1425	1460	500	310	450	502
	14	350	762	778	762	337	1585	1620	600	460	704	756
	16	400	838	854	838	387	1790	1830	500	460	923	965
	18	450	914	930	914	438	1960	2000	650	460	1131	1224
	20	500	991	1010	991	489	2158	2220	750	460	1345	1400
	24	600	1143	1165	1143	584	2576	2620	900	600	2122	2385
	28	700	1346	1372	1346	684	-	3080	-	600	-	3300
	30	750	1397	1422	1397	735	-	3180	-	600	-	3550
	32	800	1524	1553	1524	779	-	3300	-	600	-	4400
36	900	1727	1756	1727	874	-	3760	-	600	-	6050	

API Steel Gate Valve

TEK VALVE

Construction feature

- Bolted bonnet
- Flexible or solid wedge
- Renewable seat
- (Threaded or welded seat ring)
- ✓ 6" Yoke integral with bonnet
- ^ 8" Spigate yoke bolted to bonnet

API598 Pressure Test

- Pressure ratings .. Class600
- Hydraulic Shell test ..15.6MPa
- Hydraulic Seat test ..11.4MPa
- Air test ..0.6MPa

- Pressure ratings .. Class900
- Hydraulic Shell test ..23.3MPa
- Hydraulic Seat test ..17.1MPa
- Air test ..0.6MPa

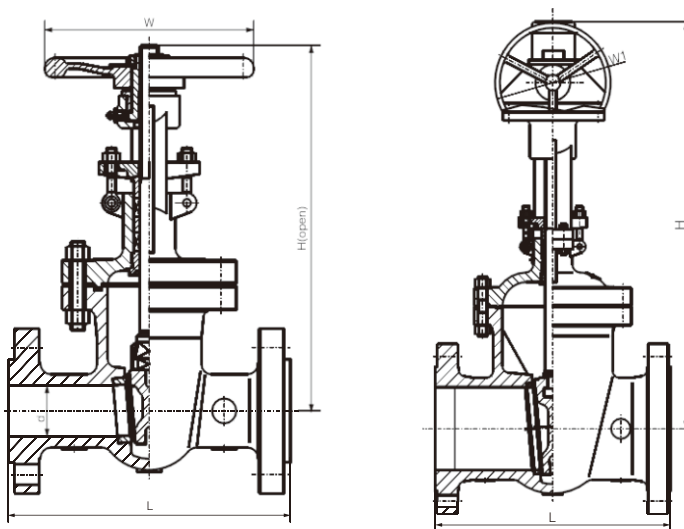

API SERIES

Main size of outside & weight

Class	Size		Dimensions (mm)								Weight (Kg)	
	NPS	DN	L			d	H	H1	W	W1	Hand wheel	Gear box
			RF	RTJ	BW							
Class 600	2	50	292	295	292	51	444	-	200	-	32	-
	2 1/2	65	330	333	330	64	500	-	250	-	52	-
	3	80	356	359	356	76	558	585	280	310	60	87
	4	100	432	435	432	102	665	695	300	310	107	134
	5	125	508	511	508	127	760	790	350	310	175	227
	6	150	559	562	559	152	868	900	450	310	216	268
	8	200	660	664	660	200	1073	1110	500	310	399	451
	10	250	787	791	787	248	1263	1300	650	460	605	657
	12	300	838	841	838	298	1600	1650	700	460	851	893
	14	350	889	892	889	327	1705	1750	900	460	1177	1232
	16	400	991	994	991	375	1835	1900	900	460	1513	1568
	18	450	1092	1095	1092	419	-	2020	-	600	-	1980
20	500	1194	1200	1194	464	-	2172	-	600	-	2460	
24	600	1397	1407	1397	559	-	2650	-	600	-	3650	
Class 900	2	50	368	371	368	47	500	-	280	-	70	-
	2 1/2	65	419	422	419	57	550	-	280	-	110	-
	3	80	381	384	381	73	610	660	300	310	140	167
	4	100	457	460	457	98	702	750	350	310	200	227
	5	125	559	562	559	121	850	900	400	310	258	285
	6	150	610	613	610	146	980	1060	500	460	358	410
	8	200	737	740	737	190	1100	1140	650	460	550	600
	10	250	838	841	838	234	1320	1370	700	460	1000	1100
	12	300	965	968	965	282	1500	1560	900	460	1215	1310
	14	350	1029	1038	1029	311	1900	1950	900	600	1600	1700
16	400	1130	1140	1130	354	2050	2100	900	600	2150	2330	

API Steel Gate Valve

TEK VALVE

Construction feature

- Bolted bonnet
- Flexible or solid wedge
- Renewable seat
(Threaded or welded seat ring)
- ∇ 6" Yoke integral with bonnet
- ∧ 8" Sparete yoke bolted to bonnet

API598 Pressure Test

- Pressure ratings .. Class1500
- Hydraulic Shell test .. 38.8MPa
- Hydraulic Seat test .. 28.5MPa
- Air test .. 0.6MPa

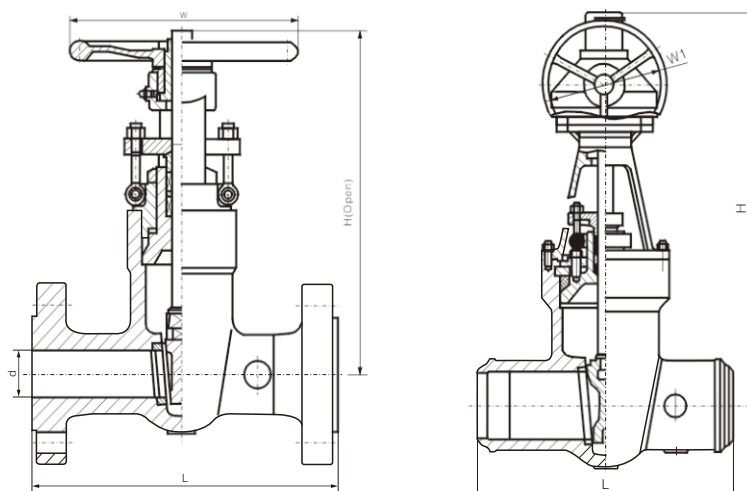

API SERIES

Main size of outside & weight

Class	Size		Dimensions (mm)								Weight (Kg)	
	NPS	DN	L			d	H	H1	W	W1	Hand wheel	Gear box
			RF	RTJ	BW							
Class 1500	2	50	368	371	368	47	510	-	280	-	70	-
	2 1/2	65	419	422	419	57	560	-	300	-	110	-
	3	80	470	473	470	70	620	670	350	310	175	202
	4	100	546	549	546	92	728	770	400	310	270	300
	5	125	673	676	673	111	870	920	450	310	378	405
	6	150	705	711	705	136	1000	1070	500	460	520	575
	8	200	832	841	832	174	1130	1180	750	460	820	915
	10	250	991	1000	991	222	1360	1410	900	600	1560	1750
	12	300	1130	1146	1130	263	-	1620	-	600	-	2120
	14	350	1257	1276	1257	289	-	2020	-	600	-	2600
16	400	1384	1407	1384	330	-	2180	-	600	-	3450	
Class 2500	2	50	451	454	451	35	530	580	280	310	100	130
	2 1/2	65	508	514	508	47	580	630	300	310	150	180
	3	80	578	584	578	57	650	700	350	310	245	275
	4	100	673	683	673	73	750	800	400	310	390	420
	5	125	794	807	794	92	900	960	500	460	550	580
	6	150	914	927	914	111	1040	1100	600	460	780	835
	8	200	1022	1038	1022	146	1150	1200	750	460	1260	1355
	10	250	1270	1292	1270	184	1400	1460	900	600	2380	2565
	12	300	1422	1445	1422	219	-	1660	-	600	-	3250